



**HANGCHA GROUP CO., LTD.**

Factory site: 666 Xiangfu Road,  
Hangzhou, Zhejiang, China (311305)

Tel: +86-571-88926735 88926755  
Fax: +86-571-88926789 88132890

sales@hcforklift.com www.hcforklift.com



Follow us on  
Facebook



Follow us on  
YouTube



Follow us on  
WeChat



Download "Hangcha  
Forklift" App



ISO45001  
ISO45001:2018



ISO14001  
ISO14001:2015



ISO9001  
ISO9001:2015



HANGCHA trucks conform  
to the European Safety  
Requirements.

# X SERIES

ELECTRIC TOW TRACTOR

With capacity of 6,000 to 18,000kg

HANGCHA GROUP CO., LTD. reserves the right to make any changes without notice concerning colors, equipment, or specifications detailed in this brochure, or to discontinue individual models. The colors of trucks, delivered may differ slightly from those in brochures.

# LET THE LUM POWER UP



## INNOVATIVE SOLUTIONS NEW POWER NOW

- / We use square lithium iron phosphate batteries and modules used in large quantities by commercial vehicles in mature economies.
- / Safe and effective: Charging efficiency as high as 95%.
- / Quick charging.
- / Long-working: 4000 charging cycles, capacity retention greater than 80%.
- / Maintenance-free: Battery does not require manual maintenance.
- / Green and clean: Pollution-free, zero emissions.

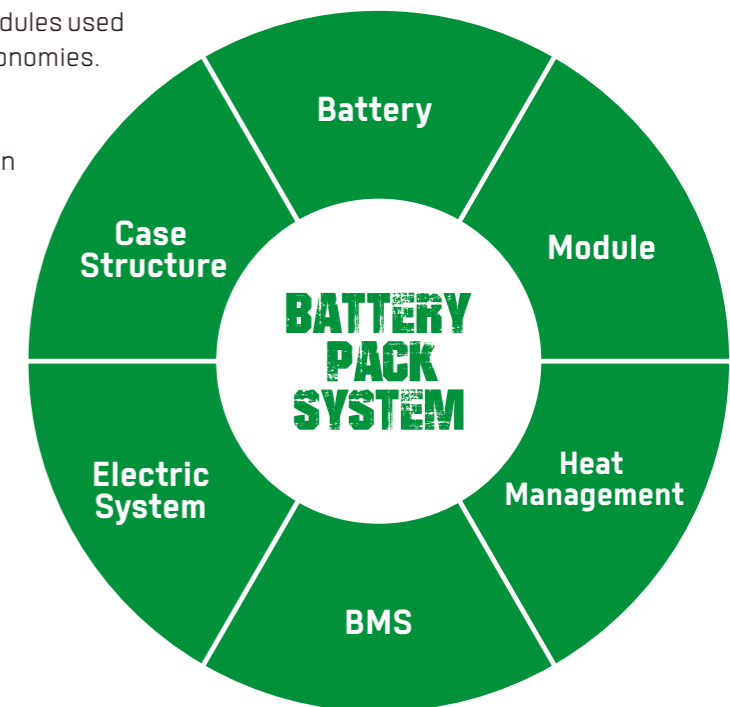

**Rapid charging and opportunity charging ensure continuous availability of vehicles**

Allow for fast full charging or boost charging. They are maintenance free and do not require a battery change when used for multi-shift operations.



**LI-ION**  
TECHNOLOGY

HANGCHA provides Li-ion battery (LiFePO4) with 6 years or 12000 hours warranty.

**6 YEARS**  
**WARRANTY**



**POWERFUL DESIGN  
TO INCREASE  
PRODUCTIVITY**



## **X SERIES ELECTRIC TOW TRACTOR**

Your reliable, powerful and connected working machine.

---

X series electric tow tractor (6-18t) are upgraded products. Through comprehensive upgrades in appearance, safety, reliability, advancement and comfort, the performance of the entire vehicle has been greatly improved compared to the original products. , to meet the traction operation needs of different users under various working conditions.



# DESIGNED AROUND THE DRIVER

Large arcs and streamlined curved surfaces to form aesthetically pleasing appearance.

The optional fully enclosed cab is applicable to all-weather operations.



The wide-view cab with an integral frame is flexibly connected to the body, and has good sealing, sound insulation, vibration isolation and heat insulation, etc. as well as a large operation space to improve the driver's comfort.



## Reliability and safety

- The main electrical components such as the motor controller, contactor, power plug and emergency cut-off switch are all quality products.
- Main force-bearing components such as the frame, drive axle and steering axle, etc. are designed to have high strength and meet heavy-duty operating conditions.
- The efficient AC power system has complete protection functions and greatly improved reliability and service life.
- Both front and rear wheels are equipped with brakes for flexible and reliable braking.



With advanced performance and forced air cooling, the fully-enclosed imported AC power system is safe and reliable.

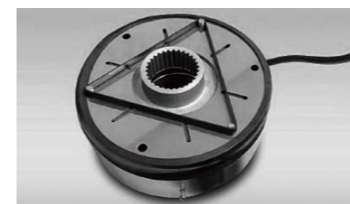

Electronic parking braking: A more convenient and safer electronic hand brake is provided.

## Stability

With the battery placed at the bottom of the vehicle frame, the vehicle has good stability.

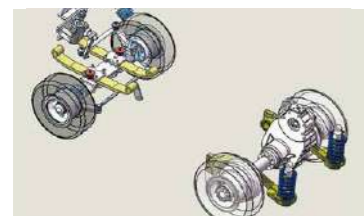
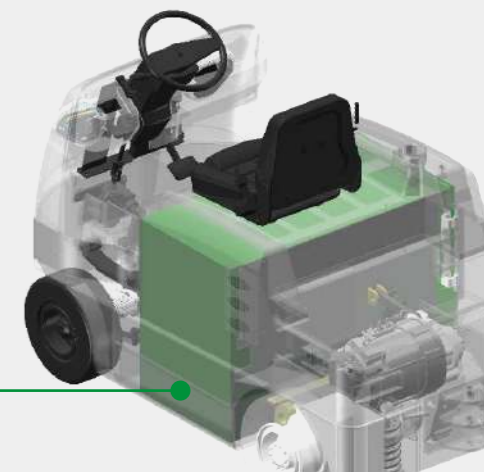

The front and rear axles equipped with a flexible suspension system offer less vibration and good comfort.



The operating pedals, instruments, hand wheel and switches are all provided according to ergonomic requirements and can be operated flexibly and easily.



Removed from a side of the vehicle, the battery provided for the standard configuration can be replaced and maintained more easily and is applicable to continuous operating conditions.

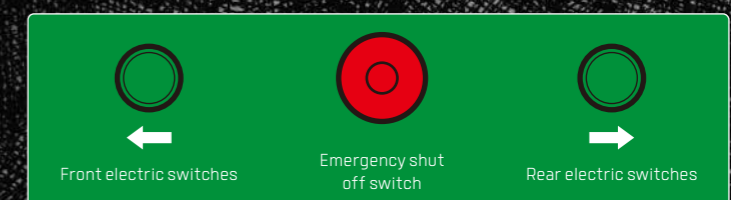

## Operating switches at the rear of the vehicle:

There are front and rear electric switches and an emergency shut-off switch to enable easy and safe hooking.

The emergency shut-off switch equipped for the standard configuration complies with European safety standards.





# REVOLUTIONARY PERFORMANCE.

- Instead of a traditional handbrake, an electromagnetic brake is used to realize the intelligent braking.
- With efficient and precise adjustment performance, the newly equipped AC control system supports longer operating hours after being charged once.
- With a driving speed up to 23km/h, the vehicle is efficient and fast.



## LED System



The vehicle is equipped with LED lights, and the front turn signal lights use streamer technology.

Integrated LED headlights with functions of such as daytime running lights, high-beam low-beam and front turning streamers, etc., streamer LED tail lights and auxiliary side turn signal lights with strong alert function and offering higher safety.

## LED-screen instruments



The large-screen LCD display and the gauges with fault self-diagnosis functions can accurately display information in harsh environments.

The LED-screen instruments have the functions of battery display, timer and fault self-diagnosis, without a handheld unit, maintenance and changing of the vehicle performance can be completed through the instruments. Faults are indicated in the form of a combination of codes and text, which are clearer and easier to read.



## Remote control (optional):

Vehicle management system: With functions of vehicle status querying and recording, overspeed, door locking and radar alarm, etc., the equipment can be equipped with a 7-inch touch screen to make operations easier, facilitate all-round data display and real-time status reminding, and enable remote real-time monitoring, management and service.



The airport type lithium battery provided for the standard configuration can be charged in a short time and fully charged in 2 hours so that operating efficiency is effectively improved.



The world's leading horizontally-placed drive unit uses a special speed reducer with a large speed reduction ratio.



## Optional battery list

	Capacity(Ah)	6t	8t	10t	12t	15t	18t
Lead-acid battery	300	●	–	–	–	–	–
	315	○	–	–	–	–	–
	345	○	–	–	–	–	–
	360	○	●	–	–	–	–
	375	○	○	–	●	–	–
	420	–	–	●	–	–	–
Lithium battery	450	–	–	○	○	●	●
	271	●	●	–	–	–	–
	302	–	–	–	●	●	–
	404	○	○	●	–	–	–
	456	–	–	–	○	○	●
604	–	–	–	○	○	○	

Note: ● Standard battery capacity ; ○ Optional battery capacity;

## Maintainability

- The brushless AC motor is maintenance-free and significantly reduces the operating cost.
- The easy-to-remove rear platform hood facilitates the commissioning and maintenance of the electrical control system.
- The battery removed from a side of the vehicle enables easy repair and maintenance of the battery.
- The electrical control and electrical components are placed together and highly integrated.



## Features

Truck	Standard	Options
Electric power steering (12 - 18t)	●	
Simple canopy (without windows and wipers)		○
Simple canopy (with windows and wipers)		○
Specifications of traction device		○
Optional imported branded battery		○
Electric power steering (6 - 10t)		○
<b>Controls and instruments</b>		
Emergency shut-off switch	●	
Large LCD display	●	
<b>Safety</b>		
Horn, reversing buzzer	●	
Acoustic and optical alarm		○
Reversing voice buzzer		○
Alarm light		○
Fire extinguisher		○
<b>Maintenance</b>		
Battery removed sideways	●	
<b>Lights</b>		
LED headlights (high-beam / low-beam), turn signal lights, combination LED three-color tail lights	●	
Blue light		○
LED rear lights		○
<b>Other</b>		
Terminal power supply		○
Ultra-elastic solid tire		○
Cloud intelligent forklift management system		○
Charger		○
Seat with safety belt	●	
Cup holder, toolbox	●	
Left and right retroreflectors (in conjunction with canopy and cab for the standard configuration)		○
Fan (in conjunction with canopy and cab)		○
Optional special seat		○
Fully enclosed cab		○
Chair sensing system		○
Decoupling hook-equipped traction pin		○