

A Series Electric Tow Tractor

Distinguishing marks	1.1	HANGCHA GROUP CO.,LTD.				
	1.2	Manufacturer's type designation	QDD3-ASC2*	QDD3-ASC2-I*	QDD5-ASC2*	QDD5-ASC2-I*
1.3	Drive	Electric	Electric	Electric	Electric	
1.4	Operator type: hand, pedestrian, standing, seated, order-picker	standing	standing	standing	standing	
1.5	Load capacity/rated load	Q (kg/lb)	3000	3000	5000	
1.7	Rated drawbar pull	F (N/lbf)	600	600	1000	
1.9	Wheelbase	y (mm/in)	957	995	978	
2.1	Service Weight	kg/lb	900	900	1000	
2.3	Axle loading, front/rear	kg/(lb)	610/290	610/290	700/300	
Wheels, Chassis	3.1	Tyres: solid rubber, superelastic, pneumatic, polyurethane	PU	PU	PU	PU
	3.2	Tyre size, front	mm/in	φ230×75	φ230×75	φ250×100
3.3	Tyre size, rear	mm/in	φ200×100	φ200×100	φ200×100	
3.5	Wheels, number front /rear (x=drive wheels)		1×/2	1×/2	1×/2	
3.7	Track width, rear	b11 (mm/in)	669	669	669	
4.8	Seat height/stand height	h7 (mm/in)	150	150	150	
4.19	Overall length(without traction pin)	l1 (mm/in)	1289	1327	1289	
4.21	Overall width	b1 (mm/in)	830	830	830	
4.32	Ground clearance, centre of wheelbase	m2 (mm/in)	70	70	70	
4.35	Turning radius	Wa (mm/in)	1172	1210	1172	
5.1	Travel speed, laden/unladen	km/h (mph)	7.0/10.0	7.0/10.0	7.0/10.0	
5.5	Drawbar pull at 60 minute rating	N/lbf	600	600	1000	
5.6	Max. Drawbar pull at 5 minute rating	N/lbf	2400	2400	3200	
5.7	Gradeability, laden	%	4	4	4	
5.10	Service brake		Electronmagnetic	Electronmagnetic	Electronmagnetic	
6.1	Drive motor rating S2 60 min.	kW/hp	2.2	2.2	3	
6.4	Battery voltage,rated capacity(STD.)	V/Ah	24/270	24/125	24/360	
	Battery voltage,rated capacity(OPT.)	V/Ah	24/360	24/228	24/450	
Others	8.1	Type of drive control	CURTIS	CURTIS	CURTIS	

Specifications are subject to change without notice.

Note: * CE model

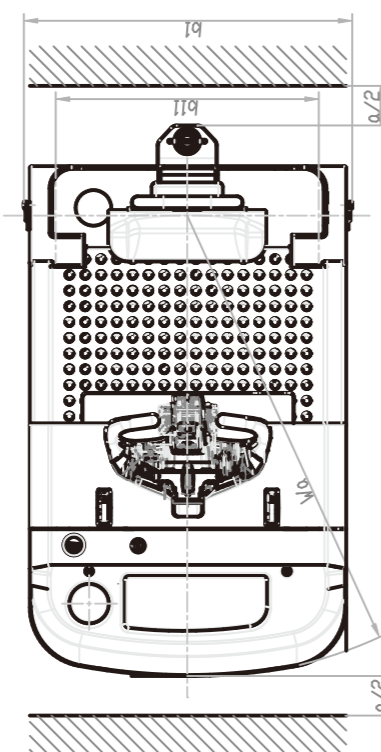
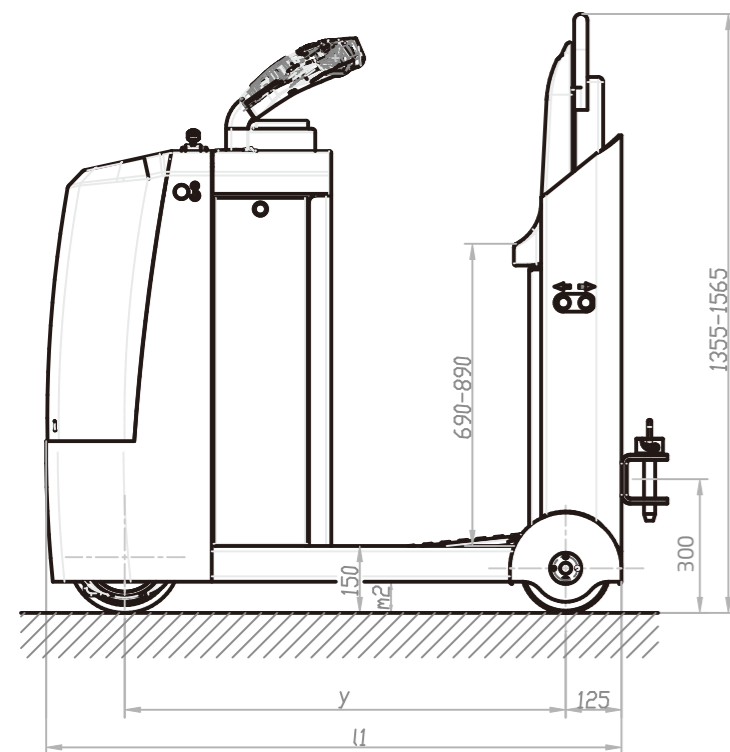

a=200mm Safety clearance



HANGCHA GROUP CO., LTD.

Factory site: 666 Xiangfu Road,
Hangzhou, Zhejiang, China (311305)

Tel: +86-571-88926735 88926755
Fax: +86-571-88926789 88132890

sales@hcforklift.com
www.hcforklift.com



Follow us on Facebook



Follow us on YouTube



Follow us on WeChat



Download "Hangcha Forklift" App



ISO45001:2018



ISO14001:2015



ISO9001:2015



HANGCHA trucks conform to the European Safety Requirements.

2024 VERSION | COPYRIGHT 2024/04

HANGCHA GROUP CO., LTD. reserves the right to make any changes without notice concerning colors, equipment, or specifications detailed in this brochure, or to discontinue individual models. The colors of trucks, delivered may differ slightly from those in brochures.



A Series Electric Tow Tractor

with capacities of 3,000 to 5,000kg

The World of Hangcha
SINCE 1956



LET THE LITHIUM POWER UNLEASH



INNOVATIVE SOLUTIONS NEW POWER NOW

Innovative, reliable lithium-ion technology (Lithium Iron-Phosphate), which are developed jointly by HANGCHA and CATL. Battery cells and modules are from CATL, with reliable quality, exclusively for HANGCHA.

- / We use square lithium iron phosphate batteries and modules used in large quantities by commercial vehicles in mature economies.
- / The module uses an aluminum alloy frame which is sturdy, lightweight and with excellent heat dissipation.
- / Safe and effective: Charging efficiency as high as 98%, thermal runaway temperature 600 °C or above.
- / Adapted to low temperatures: Comes standard with an electrical heating feature, ensuring normal operation in low temperatures.
- / Quick charging: 2 hours full charge, economic use of each break.
- / Long-working: 4000 charging cycles, capacity retention greater than 80%.
- / Maintenance-free: Battery does not require manual maintenance.
- / Green and clean: Pollution-free, zero emissions.

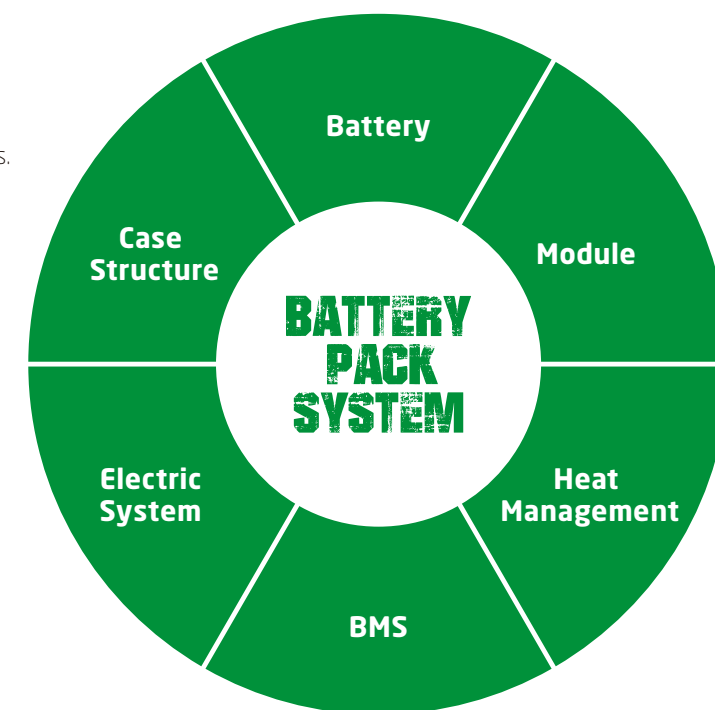

Li-Ion
2 hours
100%

Lead-acid batteries
8-10 hours 100%

Rapid charging and opportunity charging ensure continuous availability of vehicles.

Li-Ion powered forklifts are always available. They allow for fast full charging or boost charging (100 % charge in 2 hours). They are maintenance free and do not require a battery change when used for multi-shift operations.

Li-Ion Battery Pack specification

Type		QDD3-ASC2-I*	QDD5-ASC2-I*
Li-Ion battery	V/Ah	24/125	24/228
Li-Ion battery, Optional	V/Ah	24/228	-
Titans charger		SPC-24100	SPC-24100

Note: * CE model



HANGCHA provides Li-Ion battery (LiFePO4) with 6 years or 12000 hours warranty.

**6 YEARS
WARRANTY**

A Series Electric Tow Tractor

HANGCHA A series 3.0-5.0t electric tow tractor is mainly applied in short-distance transportation among the production lines. Low operator platform for frequent and effortless entry and exit. Thanks to the standing design, it can greatly improve the efficiency of operations. Furthermore, for indoor application, the electric drive system is environmental friendly within the workshop. Therefore, this product is a good partner of automobile manufacturing, logistics companies, warehouses and other places, fields which has broad application prospects.



Appearance

- / A series 3.0-5.0t electric tow tractor applied professional industrial design, stream lines, and compact, and fully ergonomic consideration, in line with the latest design trends.
- / Applied steel stamping and injection molding processes for front and back guard, which is robust, durable, and also environmental compliance.

High Performance

- / Electric power steering is standard specification, which provides flexible operation.
- / Powered by AC traction motor not only has good acceleration and climbing performance, but also low heat, brushless, maintenance-free.
- / Latest AC control system, precise and smooth.
- / CAN-BUS connection enables all truck data can be read out for inspection, and also improves the data transition more quick and reliable.
- / Regenerative braking for battery recovery during travel speed reduction, anti-slope on gradient.
- / All key parts such as switches, connectors, battery indicator and hour meter all adopt the famous brand.

Reliability

- / 3-pivot and side support bar system design ensure the safe and reliability.
- / Imported waterproof connectors, all wires and cables are protected, greatly improve the reliability of the electric system.
- / Safety switch of pedal using non-contact proximity switch, improves safety and reliability.
- / Though sideway battery change is standard specification, fixed in safe and reliable way.

Comfort

- / The pedal applies shock absorption design, greatly improve the operator's comfort, reduce the fatigue.
- / Backrest height can be adjusted within a certain range, and the backrest with hip support can greatly improve the comfort of the operator.
- / Sideway change battery is the standard specification. The inching switches installed at the LH/RH side, greatly improve the ease of operation.
- / The easy to reached storage space is convenient for the operator.
- / Compact size, light weight and flexible, extremely easy to operate, can easily go through even in a compact space.

Safety

- / Automatic deceleration during turning.
- / Pedal has a safety switch, which can effectively prevent mis-operation.
- / Three braking system of regenerative braking, reverse current braking, parking brake, insures the safe operation.
- / Steel front shield assures excellent safety for the operation.

Maintenance

- / AC motor without carbon brushes, maintenance-free, cost saving.
- / Integrated battery indicator, hour meter and self-diagnostic instrument.
- / Full opened hood, easy accessibility of all components, is easy for service.
- / All shafts are equipped with shaft sleeve and oil cup, easy maintenance, prolong service life.

Standard Specification

- / AC drive motor
- / Electric steering system
- / Inching switch(LH/RH)
- / Emergency cut off switch
- / Stand-on pedal with shock absorber
- / Adjustable supportive backrest
- / Sideway change battery
- / Battery indicator
- / Warning signal when reversing
- / Multi-function handlebar
- / Horn
- / Tool box
- / Standard lead-acid battery

Options

- / Warning light
- / Working light
- / Handrail
- / Big capacity battery
- / Turning indicators
- / Different height of towing coupling
- / Review Mirror

